

2012-07-12



5012620700-00LC

DVP01LC-SL

Instruction Sheet

Bilgi Dökümanı

安 裝 說 明

安 装 说 明

Load Cell Module

Load Cell Modülü

Load Cell 秤重模組

Load Cell 秤重模块



Thank you for choosing Delta's DVP series PLC. Delta releases DVP01LC-SL load cell module of weight measurement function. DVP01LC-SL provides 24-bit resolution applicable for 4-wire or 6-wire load cells with various eigenvalues. Therefore, the response time can be adjusted in coordination with each other according to users' needs. On this basis, the market requirements on weight measurement can easily be met.

- ✓ This instruction sheet provides introductory information on electrical specifications, general specifications, installation and wiring.
- ✓ This is an OPEN TYPE I/O module and therefore should be installed in an enclosure free of airborne dust, humidity, electric shock and vibration. The enclosure should prevent non-maintenance staff from operating the device (e.g. key or specific tools are required to open the enclosure) in case danger and damage on the device may occur.
- ✓ DO NOT connect the input AC power supply to any of the I/O terminals; otherwise serious damage may occur. Check all the wiring again before switching on the power. Make sure the ground terminal  is correctly grounded in order to prevent electromagnetic interference.
- ✓ The tightening torque for I/O terminal block is 1.95 kg-cm (1.7 in-lbs). Use 60/75°C copper conductors only.

■ Product Profile & Dimensions

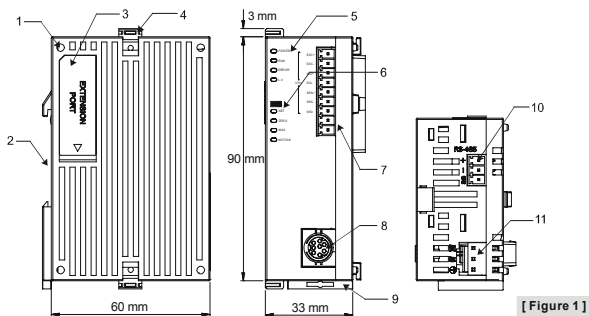

[Figure 1]

1. Mounting hole of the I/O module	2. DIN rail mounting slot (35mm)
3. I/O module connection port	4. I/O module clip
5. Status indicator (POWER, RUN, ERROR and L.V)	6. Function status indicator (NET, ZERO, MAX, MOTION)
7. I/O terminals	8. RS-232 port
9. Mounting slot clip	10. RS-485 port
11. DC power input	

■ I/O Terminal Layout

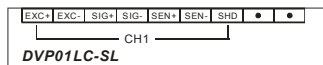

External Wiring

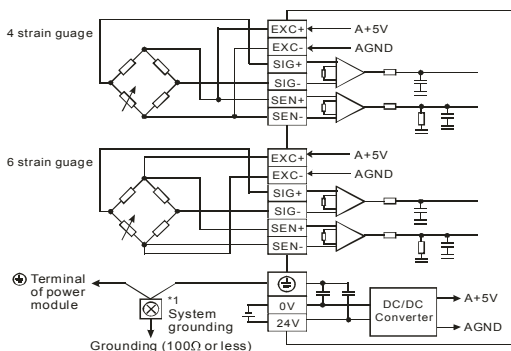

[Figure 2]

Note 1: Please connect the  terminal on both the power module and Load Cell module to the system earth point and ground the system contact or connect it to the cover of power distribution cabinet.

Electrical Specifications

Load cell module	Voltage output
Rated power supply voltage/ power consumption	24 VDC (-15 to +20%) / 3W
Voltage Boundary	18 to 31.2 VDC
Max. current consumption	125 mA
Input signal range	± 40 mVDC
Sensibility	+5 VDC +/-10%
Internal resolution	24 bits
Communication port	RS-232, RS-485
Applicable sensor type	4-wire or 6-wire strain gauge
Temperature coefficient span	$\leq \pm 50$ ppm/K v. E
Temperature coefficient zero point	$\leq \pm 0.4$ μ V/K
Linearity error	$\leq 0.02\%$
Response time	2, 10, 20, 40, 80 ms \times channels
4 measuring ranges	0 to 1 mV/V, 0 to 2 mV/V, 0 to 4 mV/V, 0 to 6mV/V
Max. distance for connecting to load cell	100 M
Max. current output	5 VDC \times 300 mA
Permitted load cell resistance	40 to 4,010 Ω
Common mode rejection (CMRR @50/60 Hz)	≥ 100 dB
Dynamic value filter	Setting range: K1 to K5
Average value filter	Setting range: K1 to K100
Isolation method	500 VAC between digital circuits and Ground 500 VAC between analog circuits and Ground 500 VAC between analog circuits and digital circuits

Load cell module	Voltage output
Series connection to DVP-PLC MPU	Connectable to the left side of MPU, numbered from 100 to 107 according to the position of module from the closest to farthest to MPU.
Operation / storage temperature	Operation: 0 to 55°C (temp.), 50 to 95% (humidity), pollution degree 2 Storage: -25 to 70°C (temp.), 5 to 95% (humidity)
Vibration / shock immunity	International standards: IEC61131-2, IEC 68-2-6 (TEST Fc)/ IEC61131-2 & IEC 68-2-27 (TEST Ea)

- ❖ Complying with DIN1319-1, the tolerance of measured value should be $\leq 0.05\%$ under 20°C + 10K temperature range.
- ❖ When the corrected ambient temperature and the actual temperature have a difference of more than 10°C, it is suggested that you re-correct it.

■ Control Register

CR#	Add.	Attrib.		Register name	Explanation
#0	H1000	O	R	Model name	Set up by the system: DVP01LC-SL model code = H'4106
#1	H1001	O	R	Firmware version	Displaying the current firmware version in hex.
#2	H1002	O	R/W	Eigenvalue	Mode 0 (H'0000): 1 mV/V Mode 1 (H'0001): 2 mV/V, default Mode 2 (H'0002): 4 mV/V Mode 3 (H'0003): 6 mV/V
#3	H1003	O	R/W	Reaction time for measurement	Mode 0 (H'0000): 2 ms Mode 1 (H'0001): 10 ms Mode 2 (H'0002): 20 ms Mode 3 (H'0003): 40 ms Mode 4 (H'0004): 80 ms, default
#6	H1006	X	R/W	Tare gotten from CH1	Reading the present average value as tare bit0: CH1
#7	H1007	O	R/W	Gross/Net weight	Taking the present weight as the gross weight (K0) or the net weight (K1).
#10	H100A	O	R/W	Average number of times gotten from CH1	Default: K10; Range: K1~K100 If the setting value exceeds the range, it will be automatically changed to K1 or K100.
#12	H100C	X	R	Weight gotten from CH1 (Low word)	Displaying the weight. Default: K0
#13	H100D	X	R	Weight gotten from CH1 (High word)	Displaying the weight. Default: K0
#16	H1010	O	R/W	Number of times the stability of the values gotten from CH1 is checked	Default: K5; Range: K1~K500
#18	H1012	O	R/W	Range within which the stability of the values gotten from CH1 is checked	Default: K10; Range: K1~K10,000
#20	H1014	O	R/W	Number of decimal places gotten from CH1	Default: K2; Range: K1~K4
#22	H1016	O	R/W	Unit of measurement for weight gotten from CH1	Four ASCII words at most

CR#	Add.	Attrib.		Register name	Explanation
#23	H1017	O	R/W	Unit of measurement for weight gotten from CH1	CR#22 and CR#24: High word CR#23 and CR#25: Low word
#26	H101A	X	R/W	Weight correction command	For correcting the weight Default: H'0000 H'0001: Reset the weight gotten from CH1 to zero H'0002: The weight of the weights gotten from CH1
#33	H1021	O	R/W	Weight of the weights gotten from CH1	The default in CR#33 and CR#34 is K1,000. Range: K-32,768~K32,767 Steps for the correction: 1: Place no weights on the load cell 2: Write H'000 into CR#26. 3: Place standard weights on the load cell. 4: Write the weight of the weights on the plate into CR#33. 5: Write H'0002 into CR#26.
#35	H1023	O	R	Maximum weight gotten from CH1 (Low word)	The user can set the maximum weight. If the weight gotten is larger than the maximum weight set by the user, the error code will be recorded.
#36	H1024	O	R	Maximum weight gotten from CH1 (High word)	
#37	H1025	O	R/W	Upper limit for taking the weight gotten from CH1 as zero	For judging the zero status If the weight is within this range, the status code will be a zero bit, indicating that there are no weights. Default: K10 Range: K-32,768 to K32,767
#39	H1027	O	R/W	Lower limit for taking the weight gotten from CH1 as zero	For judging the zero status If the weight is within this range, the status code will be a zero bit, indicating that there is no weight. Default: K-10 Range: K-32,768 to K32,767
#41	H1029	X	R/W	Storing the setting value (H'5678)	The present setting value is stored. All setting values are written into the internal flash memory so that they can be used next time DVP01LC-SL is turned on. H0: No action (default) H'FFFF: The value is stored successfully. H'5678: All setting values are written into the internal flash memory. After H'5678 is written into the register, all setting values will be stored in the flash memory. After the values are stored, the value in CR#41 becomes H'FFFF. If the value written into the register is not H'5678, the value will automatically return to H0. For example, if K1 is written into the register, K1 will return to K0.
#43	H102B	X	R/W	Setting the percentage of signals filtered for CH1	Default: K2Range: K1 to K9 (Unit: 10%)

CR#	Add.	Attrib.		Register name	Explanation
#50	H1032	X	R	Status code	b0 (H'0001): The weight gotten from CH1 is zero. (No load) b2 (H'0004): The weight gotten from CH1 exceeds the maximum weight. (Overload) b4 (H'0010): The measured value gotten from CH1 is stable. b6 ~ b15: Reserved
#51	H1033	X	R	Error code	All error statuses are stored in the register. See "Error Code Table" below. Default: H'0000
#52	H1034	O	RW	RS-232 station address	The default in CR#52 and CR#54 is K1. Range: K1~K255 The default in CR#53 and CR#55 is H'0000; Range: ASCII, 9600, 7, E, 1. See "Communication Format Table" below.
#53	H1035	O	RW	RS-232 communication format	
#54	H1036	O	RW	RS-485 station address	
#55	H1037	O	RW	RS-485 communication format	
Symbols: O indicates that the register is a latched register. X indicates that the register is not a latched register. R indicates that the data can be read. W indicates that the data can be written.					

▲ Error Code Table for CR#51:

bit	Value	Error	bit	Value	Error
b0	K1 (H'0001)	The power supply is abnormal.	b1	K2 (H'0002)	The hardware breaks down.
b2	K4 (H'0004)	The conversion gotten from CH1 is incorrect.	b3	K8 (H'0008)	The voltage of SEN in CH1 is incorrect.
b6 ~ b15	K64 (H'0040)	Reserved			
<i>Note:</i> Every error status depends on its corresponding bit. There may be more than two error statuses occurring at the same time. 0 indicates that there is no error. 1 indicates that an error occurs.					

▲ Communication Format Table for CR#53, CR#55:

bit15	bit14~bit8	bit7	bit6	bit5	bit4	bit3	bit2	bit1	bit0
ASCII/RTU	Reserved	Serial transmission speed				Data length	Stop bit	Parity bit	
Description									
bit15	ASCII/RTU			0	ASCII	1	RTU		
bit7~bit4	Serial transmission speed			0	9,600 bps	1	19,200 bps		
				2	38,400 bps	3	57,600 bps		
				4	115,200 bps	5	Else none		
bit3	Data length (RTU = 8 bits)			0	7	1	8		
bit2	Stop bit			0	1 bit	1	2 bits		
bit1~bit0	Parity bit			0	Even	1	Odd		
				2	None	3	None		

感謝您採用台達 DVP 系列產品。台達再度推出 Load Cell 秤重量測模組 DVP01LC-SL。DVP01LC-SL 提供 24-bit 高解析度，可適用 4 或 6 線式的多種特徵值 Load Cell，可配合客戶需求進行反應速度的搭配調整，輕易地滿足目前荷重應用市場上的全面需求。

- ✎ 請在使用之前，詳細閱讀本使用說明書。
- ✎ 實施配線前，務必關閉電源。於輸入電源切斷後，一分鐘之內，請勿觸摸內部電路。
- ✎ 本機為開放型 (OPEN TYPE) 機殼，因此使用者使用本機時，必須將之安裝於具防塵、防潮及免於電擊/衝擊意外之外殼配線箱內。另必須具備保護措施 (如：特殊之工具或鑰匙才可打開) 防止非維護人員操作或意外衝擊本體，造成危險及損壞。
- ✎ 交流輸入電源不可連接於輸入/輸出信號端，否則可能造成嚴重損壞，請在上電之前再次確認電源配線，並請勿在上電時觸摸任何端子。
- ✎ 本體上之接地端子  務必正確的接地，可提高產品抗雜訊能力。
- ✎ 端子螺絲扭力為 1.95 kg-cm (1.7 in-lbs)，並請使用 60/75°C 銅導線。

■ 產品外觀尺寸與部位介紹

詳細圖示請參閱英文版頁碼 1 之 [Figure 1]，單位：mm。



1. I/O 模組定位孔	2. DIN 導軌槽 (35mm)
3. I/O 模組連接埠	4. I/O 模組固定扣
5. 電源、運行、錯誤及低電壓指示燈 (POWER, RUN, ERROR, L.V)	6. 通道淨重、零點、最大值、穩定功能狀態燈 (NET, ZERO, MAX, MOTION)
7. I/O 端子	8. RS-232 通訊埠
9. DIN 軌固定扣	10. RS-485 通訊埠
11. 電源輸入口	

■ 輸入/輸出端子台配置

請參閱英文版頁碼 1 之端子配置圖，在此語言版本省略說明。

■ 外部配線

詳細圖示請參閱英文版頁碼 2 之 [Figure 2]。

註 1：請將電源模組之  端及 Load Cell 秤重量測模組之  端連接到系統接地點，再將系統接地點作第三種接地或接到配電箱之機殼上。

■ 規格

Load cell 模組	電壓輸出
電源額定電壓/消耗功率	24 VDC (-15 ~ +20%) / 3W
電壓範圍	18 ~ 31.2 VDC
最大消耗電流	125 mA
輸入訊號範圍	±40 mVDC
感測度	+5 VDC +/-10%
內部解析度	24 bits
通訊介面	RS-232, RS-485
適合感應器形式	4 線制或 6 線制荷重單元 (Load Cell)
溫度係數擴展	≤ ± 50 ppm/K v. E
溫度係數偏移	≤ ± 0.4 μV/K

Load cell 模組	電壓輸出
線性誤差	≤ 0.02%
反應時間	2, 10, 20, 40, 80 ms × 通道數
適用 Load Cell 特徵值	0 ~ 1, 0 ~ 2, 0 ~ 4, 0 ~ 6 mV/V
連接 Load Cell 最大距離	100 公尺
最大輸出電流	5 VDC * 300 mA
允許負載能力	40 ~ 4,010 Ω
共模拒斥比 (CMRR @50/60 Hz)	100dB 以上
動態值濾波	可設定範圍 K1 ~ K5
平均功能	可設定範圍 K1 ~ K100
隔離方式	數位電路與接地之間：500 VAC 類比電路與接地之間：500 VAC 類比電路與數位電路之間：500 VAC
與 DVP-PLC 主機 連接說明	連接於主機左側，模組編號依靠近主機之順序自動編號由 100 到 107。
操作/儲存環境	操作：0 ~ 55°C (溫度) · 50 ~ 95% (濕度) · 污染等級 2 儲存：-25 ~ 70°C (溫度) · 5 ~ 95% (濕度)
耐振動衝擊	國際標準規範 IEC 61131-2, IEC 68-2-6 (TEST Fc)/IEC 61131-2 & IEC 68-2-27 (TEST Ea)

- ❖ 符合 DIN1319-1 在量測範圍最終值為 20°C + 10K 的錯誤極限需 ≤ 0.05%。
- ❖ Load Cell 校正環境溫度與實際操作溫度相差 10°C 以上時，建議重新校正以獲得最佳精確值。

■ 控制暫存器 CR

CR#	位址	屬性		暫存器名稱	說明
#0	H1000	O	R	機種型號	系統內定 · DVP01LC-SL 機種代碼 = H'4106
#1	H1001	O	R	韌體版本	16 進制 · 顯示目前韌體版本
#2	H1002	O	R/W	特徵值	模式 0 (H'0000)：1 mV/V 模式 1 (H'0001)：2 mV/V (預設值) · 模式 2 (H'0002)：4 mV/V 模式 3 (H'0003)：6 mV/V
#3	H1003	O	R/W	量測反應時間	模式 0 (H'0000)：2 ms 模式 1 (H'0001)：10 ms 模式 2 (H'0002)：20 ms 模式 3 (H'0003)：40 ms 模式 4 (H'0004)：80 ms (預設值) ·
#6	H1006	X	R/W	CH1 去皮	讀取目前的平均值做為皮重的重量值 bit0：CH1 ·
#7	H1007	O	R/W	毛重 / 淨重顯示設定	選擇目前重量顯示為毛重 (K0) 或淨重 (K1) ·
#10	H100A	O	R/W	CH1 平均次數	設定範圍在 K1 ~ K100 · 預設值 K10 · 設定值超過範圍時，則自動變更為臨界值 K1 或 K100 ·
#12	H100C	X	R	CH1 重量值 (Low word)	重量值顯示 · 預設值 K0 ·

CR#	位址	屬性		暫存器名稱	說明
#13	H100D	X	R	CH1 重量值 (High word)	重量值顯示，預設值 K0。
#16	H1010	O	R/W	CH1 穩定檢查次數	預設值 K5，設定值範圍 K1 ~ K500。
#18	H1012	O	R/W	CH1 穩定檢查範圍	預設值 K10，設定值範圍 K1 ~ K10000。
#20	H1014	O	R/W	CH1 小數點位數設定	設定範圍在 K1 ~ K4，預設值 K2。
#22	H1016	O	R/W	CH1 重量量測單位	ASCII 輸入，最多四個字元。
#23	H1017	O	R/W	CH1 重量量測單位	CR#22, CR#24 為 high word CR#23, CR#25 為 low word
#26	H101A	X	R/W	調校重量指令	使用者調校重量使用，預設值 H'0000。 H'0001：CH1 歸零指令 H'0002：CH1 砝碼基點指令
#33	H1021	O	R/W	CH1 砝碼基點重量	CR#33 ~ CR#34 預設值 K1000，設定值範圍 K-32768 ~ K32767。使用者調整步驟： Step1：荷重單元(Load Cell)上不放置任何砝碼 Step2：CR#26 設定調整指令為"H'0001" Step3：荷重單元(Load Cell)上加上標準砝碼 Step4：將目前底盤上的砝碼重量寫入 CR#33 Step5：CR#26 設定調整指令為"H'0002"
#35	H1023	O	R	CH1 重量上限 (Low word)	使用者可設定最大重量值，當量測值超出設定值時會記錄錯誤碼。
#36	H1024	O	R	CH1 重量上限 (High word)	
#37	H1025	O	R/W	CH1 零點判斷檢查範圍上限	歸零狀態判斷參考，當重量值在此範圍內，狀態碼會設定為歸零位元 (zero bit)，表示目前是空載狀態。 預設值 K10，設定值範圍 K-32768 ~ K32767。
#39	H1027	O	R/W	CH1 零點判斷檢查範圍下限	歸零狀態判斷參考，當重量值在此範圍內，狀態碼會設定為歸零位元 (zero bit)，表示目前是空載狀態。 預設值 K-10，設定值範圍 K-32768 ~ K32767。
#41	H1029	X	R/W	儲存設定值 (H'5678)	儲存目前設定值，將目前所有設定值寫入內存 Flash，以待下次開機使用。 H0：不動作 (預設值)。 H'FFFF：儲存成功 H'5678：寫入內存 寫入 H'5678 時會將所有設定值儲存於 Flash 中，當儲存完成後，CR#41 為 H'FFFF。若寫入值不為 H'5678，則自動回復為 H0。例如 CR# 寫入 K1，會回復為 K0。
#43	H102B	X	R/W	CH1 濾波比例設定	預設值 K2，設定值範圍 K1 ~ K9(單位:10%)。
#50	H1032	X	R	狀態代碼	b0 (H'0001)：CH1 零點重量 (空載) b2 (H'0004)：CH1 超出重量上限 (超載) b4 (H'0010)：CH1 量測值穩定 b6 ~ b15：保留

CR#	位址	屬性		暫存器名稱	說明
#51	H1033	X	R	錯誤代碼	儲存所有錯誤狀態的資料暫存器。請參照錯誤資訊表。預設值為 H'0000。
#52	H1034	O	R/W	RS-232 站號	CR#52、CR#54 預設值 K1。設定值範圍 K1~K255。
#53	H1035	O	R/W	RS-232 通訊格式	
#54	H1036	O	R/W	RS-485 站號	CR#53、CR#55 通設格式。預設值 H'0000。設定值範圍 ASCII, 9600, 7, E, 1。請參照通訊格式資訊表。
#55	H1037	O	R/W	RS-485 通訊格式	
符號定義：O 表示為保持型。X 表示為非保持型。 R 表示為可讀取資料。W 表示為可寫入資料。					

※ CR#51 錯誤狀態表：

bit	內容值	錯誤狀態	bit	內容值	錯誤狀態
b0	K1 (H'0001)	電源異常	b1	K2 (H'0002)	硬體故障
b2	K4 (H'0004)	CH1 轉換錯誤	b3	K8 (H'0008)	CH1 SEN 電壓錯誤
b6 ~ b15	K64 (H'0040)	保留			
註：每個錯誤狀態由相對應之位元決定。有可能會同時產生兩個以上之錯誤狀態。0 代表正常無錯誤。1 代表有錯誤狀態產生。					

※ CR#53、CR#55 通訊格式：

bit15	bit14~bit8	bit7	bit6	bit5	bit4	bit3	bit2	bit1	bit0
ACSII/RTU	保留	串列傳輸速率			資料長度	停止位元	同位元		
說明									
bit15	ACSII/RTU			0	ASCII	1	RTU		
bit7~bit4	串列傳輸速率			0	9,600 bps	1	19,200 bps		
				2	38,400 bps	3	57,600 bps		
				4	115,200 bps	5	Else none		
bit3	資料長度 (RTU = 8 bits)			0	7	1	8		
bit2	停止位元			0	1 bit	1	2 bits		
bit1~bit0	同位元			0	Even	1	Odd		
				2	None	3	None		

感谢您采用台达 DVP 系列产品。台达再度推出 Load Cell 秤重测量模块 DVP01LC-SL。DVP01LC-SL 提供 24-bit 高分辨率，可适用 4 或 6 线式的多种特征值 Load Cell，可配合客户需求进行反应速度的搭配调整，轻易地满足目前荷重应用市场上的全面需求。

- ✎ 请在使用之前，详细阅读本使用说明书。
- ✎ 实施配线前，务必关闭电源。于输入电源切断后，一分钟之内，请勿触摸内部电路。
- ✎ 本机为开放型 (OPEN TYPE) 机壳，因此使用者使用本机时，必须将其安装于具防尘、防潮及免于电击/冲击意外的外壳配线箱内。另必须具备保护措施（如：特殊的工具或钥匙才可打开）防止非维护人员操作或意外冲击本体，造成危险及损坏。
- ✎ 交流输入电源不可连接于输入/出信号端，否则可能造成严重损坏，请在上电之前再次确认电源配线。请勿在上电时触摸任何端子。本体上的接地端子  务必正确的接地，可提高产品抗干扰能力。
- ✎ 端子螺丝扭力为 1.95 kg-cm (1.7 in-lbs)，并请使用 60/75°C 铜导线。

■ 产品外观尺寸与部位介绍

详细图示请参阅英文版页码 1 之[Figure 1]，单位：mm。



1. I/O 模块定位孔	2. DIN 导轨槽 (35mm)
3. I/O 模块连接端口	4. I/O 模块固定扣
5. 电源、运行、错误及低电压指示灯 (POWER, RUN, ERROR, L.V)	6. 通道净重、零点、最大值、稳定功能状态灯 (NET, ZERO, MAX, MOTION)
7. I/O 端子	8. RS-232 通讯端口
9. DIN 轨固定扣	10. RS-485 通讯端口
11. 电源输入口	

■ 输入/输出端子台配置

请参阅英文版页码 1 之端子配置图，在此语言版本省略说明。

■ 外部配线

详细图示请参阅英文版页码 2 之[Figure 2]。

注 1：请将电源模块的  端及 Load Cell 秤重测量模块的  端连接到系统接地点，再将系统接点作第三种接地或接到配电箱的机壳上。

■ 规格

Load cell 模块	电压输出
电源额定电压/消耗功率	24VDC (-15% ~ +20%) / 3W
电压范围	18 ~ 31.2 VDC
最大消耗电流	125 mA
输入讯号范围	±40 mVDC
感测度	+5 VDC +/-10%
内部分辨率	24 bits
通讯接口	RS-232, RS-485
适合感应器形式	4 线制或 6 线制荷重单元(Load Cell)
温度系数扩展	≤ ± 50 ppm/K v. E
温度系数偏移	≤ ± 0.4 μV/K
线性误差	≤ 0.02%

Load cell 模块	电压输出
响应时间	2, 10, 20, 40, 80 ms × 通道数
适用 Load Cell 特征值	0 ~ 1, 0 ~ 2, 0 ~ 4, 0 ~ 6 mV/V
连接 Load Cell 最大距离	100 公尺
最大输出电流	5 VDC * 300 mA
允许负载能力	40 ~ 4,010 Ω
共模拒斥比 (CMRR @50/60 Hz)	100dB 以上
动态值滤波	可设定范围 K1 ~ K5
平均功能	可设定范围 K1 ~ K100
隔离方式	数字量电路与接地之间: 500 VAC 模拟量电路与接地之间: 500 VAC 模拟量电路与数字量电路之间: 500 VAC
与 DVP-PLC 主机 连接说明	连接于主机左侧, 模块编号依靠近主机之顺序自动编号由 100 到 107。
操作/储存环境	操作: 0 ~ 55°C (温度) · 50 ~ 95% (湿度) · 污染等级 2 储存: -25 ~ 70°C (温度) · 5 ~ 95% (湿度)
耐振动/冲击	国际标准规范 IEC 61131-2, IEC 68-2-6 (TEST Fc)/IEC 61131-2 & IEC 68-2-27 (TEST Ea)

- ❖ 符合 DIN1319-1 在测量范围最终值为 20°C + 10K 的错误极限需 ≤ 0.05%。
- ❖ Load Cell 校正环境温度与实际操作温度相差 10°C 以上时, 建议重新校正以获得最佳精确值。

■ 控制寄存器 CR

CR#	位址	属性	寄存器名称	说明
#0	H1000	O R	机种型号	系统内定 · DVP01LC-SL 机种代码 = H'4106
#1	H1001	O R	韧体版本	16 进制, 显示目前韧体版本
#2	H1002	O R/W	特征值	模式 0 (H'0000): 1 mV/V 模式 1 (H'0001): 2 mV/V · 默认值。 模式 2 (H'0002): 4 mV/V 模式 3 (H'0003): 6 mV/V
#3	H1003	O R/W	测量反应时间	模式 0 (H'0000): 2 ms 模式 1 (H'0001): 10 ms 模式 2 (H'0002): 20 ms 模式 3 (H'0003): 40 ms 模式 4 (H'0004): 80 ms · 默认值。
#6	H1006	X R/W	CH1 去皮	读取目前的平均值做为皮重的重量值 bit0: CH1。
#7	H1007	O R/W	毛重 / 净重显示设定	选择目前重量显示为毛重 (K0) 或净重 (K1)。
#10	H100A	O R/W	CH1 平均次数	设定范围在 K1 ~ K100, 默认值 K10。 设定值超过范围时, 则自动变更为临界值 K1 或 K100。
#12	H100C	X R	CH1 重量值 (Low word)	平均重量值显示
#13	H100D	X R	CH1 重量值 (High word)	平均重量值显示

CR#	位址	属性		寄存器名称	说明
#16	H1010	O	R/W	CH1 稳定检查次数	默认值 K5 · 设定值范围 K1 ~ K500。
#18	H1012	O	R/W	CH1 稳定检查范围	默认值 K10 · 设定值范围 K1 ~ K10000。
#20	H1014	O	R/W	CH1 小数点位数设定	设定范围在 K1 ~ K4 · 默认值 K2。
#22	H1016	O	R/W	CH1 重量测量单位	ASCII 输入 · 最多四个字符。
#23	H1017	O	R/W	CH1 重量测量单位	CR#22, CR#24 为 high word CR#23, CR#25 为 low word
#26	H101A	X	R/W	调校重量指令	使用者调校重量使用 · 默认值 H'0000。 H'0001: CH1 归零指令 H'0002: CH1 砝码基点指令
#33	H1021	O	R/W	CH1 砝码基点重量	CR#33 ~ CR#34 默认值 K1000 · 设定值范围 K-32768 ~ K32767。使用者调整步骤： Step1: 荷重单元(Load Cell)上不放任何砝码 Step2: CR#26 设定调整指令为“H'0001” Step3: 荷重单元(Load Cell)上加上标准砝码 Step4: 将目前底座上的砝码重量写入 CR#33 Step5: CR#26 设定调整指令为“H'0002”
#35	H1023	O	R	CH1 重量上限 (Low word)	使用者可设定最大重量值 · 当量测值超出设定值时会记录错误码。
#36	H1024	O	R	CH1 重量上限 (High word)	
#37	H1025	O	R/W	CH1 零点判断检查范围上限	归零状态判断参考 · 当重量值在此范围内 · 状态码会设定为归零位(zero bit) · 表示目前是空载状态。 默认值 K10 · 设定值范围 K-32768 ~ K32767。
#39	H1027	O	R/W	CH1 零点判断检查范围下限	归零状态判断参考 · 当重量值在此范围内 · 状态码会设定为归零位(zero bit) · 表示目前是空载状态。 默认值 K-10 · 设定值范围 K-32768 ~ K32767。
#41	H1029	X	R/W	储存设定值 (H'5678)	储存目前设定值 · 将目前所有设定值写入内存 Flash · 以待下次开机使用。 H0: 不动作 (默认值) H'FFFF: 储存成功 H'5678: 写入内存 写入 H'5678 时会将所有设定值储存于 Flash 中 · 当储存完成后 · CR#41 为 H'FFFF。若写入值不为 H'5678 · 则自动回复为 H0。例如 CR# 写入 K1 · 会回复为 K0。
#43	H102B	X	R/W	CH1 滤波比例设定	默认值 K2 · 设定值范围 K1 ~ K9(单位 :10%)
#50	H1032	X	R	状态代码	b0 (H'0001): CH1 零点重量 (空载) b2 (H'0004): CH1 超出重量上限 (超载) b4 (H'0010): CH1 测量值稳定 b6 ~ b15: 保留
#51	H1033	X	R	错误代码	储存所有错误状态的数据缓存器 · 请参照错误信息表 · 默认值为 H'0000。

CR#	位址	属性	寄存器名称	说明
#52	H1034	O R/W	RS-232 站号	CR#52、CR#54 默认值 K1，设定值范围 K1 ~ K255。 CR#53、CR#55 通设格式，默认值 H'0000，设定值范围 ASCII, 9600, 7, E, 1，请参照通讯格式信息表。
#53	H1035	O R/W	RS-232 通讯格式	
#54	H1036	O R/W	RS-485 站号	
#55	H1037	O R/W	RS-485 通讯格式	
符号定义：O 表示为保持型。X 表示为非保持型。 R 表示为可读取数据。W 表示为可写入数据。				

※ CR#51 错误状态表：

Bit	内容值	错误状态	Bit	内容值	错误状态
b0	K1 (H'0001)	电源异常	b1	K2 (H'0002)	硬件故障
b2	K4 (H'0004)	CH1 转换错误	b3	K8 (H'0008)	CH1 SEN 电压错误
b6 ~ b15	K64 (H'0040)	保留			
注：每个错误状态由相对应之位决定，有可能会同时产生两个以上之错误状态，0 代表正常无错误，1 代表有错误状态产生。					

※ CR#53、CR#55 通讯格式：

bit15	bit14~bit8	bit7	bit6	bit5	bit4	bit3	bit2	bit1	bit0
ASCII/RTU	保留	波特率			数据长度	停止位	同位		
说明									
bit15	ASCII/RTU			0	ASCII	1	RTU		
bit7~bit4	波特率	0	9,600 bps		1	19,200 bps			
		2	38,400 bps		3	57,600 bps			
		4	115,200 bps		5	Else none			
bit3	数据长度 (RTU = 8 bits)			0	7	1	8		
bit2	停止位			0	1 bit	1	2 bits		
bit1~bit0	同位	0	Even		1	Odd			
		2	None		3	None			

Delta'nın DVP serisi PLC'lerini seçtiğiniz için teşekkürler. Delta, load cell ile ağırlık ölçümü için DVP01LC-SL modülünü sunar. DVP01LC-SL, 4-telli ve 6-telli özgün değerli yük hücreleri (load cell) için uygulanabilir 24-bit çözünürlük sağlar. Buna bağlı olarak, cevap zamanı (response time) kullanıcı ihtiyaçlarına göre herbiri ile koordinasyon halinde çalışma için ayarlanabilir. Bu temelde, ağırlık ölçümünde pazar ihtiyaçları rahatça karşılanabilir.

- ✓ Bu bilgi dökümanı ürünün elektriksel özellikleri, genel özellikleri, kurulumu ve bağlantısı ile ilgili bilgiler sağlar.
- ✓ Bu ürün AÇIK TİP I/O modülü olduğu için toz, nem, elektrik şoku ve titreşimden uzak yerlere kurulumu yapılmalıdır. Ürünün zarar görmemesi ve tehlike durumları oluşmaması için yetkili olmayan kişilerin ürüne müdahale etmesini önleyecek koruyucu önlemler alınmalıdır. (Örneğin ürünün bulunduğu panoya kilit konulması gibi).
- ✓ Ürünün I/O terminallerine AC besleme bağlamayınız; aksi halde ciddi zararlar meydana gelebilir. Ürüne enerji vermeden önce tüm bağlantıların doğru olduğunu tekrar kontrol ediniz. Elektromanyetik gürültüyü önlemek için toprak terminalinin ⚡ düzgün topraklandığından emin olunuz.
- ✓ I/O terminal bloğu sıkma torku 1.95 kg-cm (1.7 in-lbs) olmalı ve sadece 60/75°C bakır iletkenler kullanılmalıdır.

■ Ürün Profili & Ölçüler

İngilizce bölümde Şekil 1 [Figure 1]'e bakınız. Birim = mm

1. I/O modülü montaj yuvası	2. DIN ray montaj slotu (35mm)
3. I/O modül bağlantı portu	4. I/O modül klip
5. Durum indikatör (POWER, RUN, ERROR ve L.V)	6. Fonksiyon durum göstergesi (NET, ZERO, MAX, MOTION)
7. I/O terminaller	8. RS-232 port
9. Montaj slot klipsi	10. RS-485 port
11. DC besleme girişi	

■ I/O Terminal Yerleşimi

İngilizce bölümde "terminal layout" şekline bakınız.

■ Harici Bağlantı

İngilizce bölümde Şekil 2 [Figure 2]'ye bakınız.

Not 1: Power modülü ve load cell modülü ⚡ terminallerini sistemin toprak ucunda birleştirdikten sonra topraklamayı güç dağıtım panelinin kasasına bağlayarak yapınız.

■ Elektriksel Özellikler

Load cell modülü	Voltaj çıkışı
Besleme voltajı /Güç tüketimi aralığı	24 VDC (-15 to +20%) / 3W
Voltaj sınırları	18 to 31.2 VDC
Max. akım tüketimi	125 mA
Giriş sinyal aralığı	±40 mVDC
Hassasiyet	+5 VDC +/-10%
Dahili çözünürlük	24 bits

Load cell modülü	Volta j çıkışı
Haberleşme portu	RS-232, RS-485
Uygulanabilir sensör tipi	4-telli veya 6-telli gerinim ölçer
Sıcaklık span Katsayısı	$\leq \pm 50$ ppm/K v. E
Sıcaklık zero point Katsayısı	$\leq \pm 0.4$ μ V/K
Linearite hatası	$\leq 0.02\%$
Cevap Zamanı	2, 10, 20, 40, 80 ms \times kanal
4 ölçme aralığı	0 to 1 mV/V, 0 to 2 mV/V, 0 to 4 mV/V, 0 to 6mV/V
Load cell bağlantısı için maksimum mesafe	100m
Max. Akım çıkışı	5 VDC * 300 mA
Müsade edilen load cell direnci	40 to 4,010 Ω
Ortak mod reddetme (CMRR @50/60 Hz)	≥ 100 dB
Dinamik değer filtresi	Ayar aralığı: K1 to K5
Ortalama değer filtresi	Ayar aralığı: K1 to K100
İzolasyon metodu	Dijital devreler ve Ground arası 500 VAC Analog devreler ve ground arası 500 VAC Analog devreler ve dijital devreler arası 500 VAC
DVP-PLC MPU'ya seri bağlantı	MPU'nun sol kenarına bağlanabilir, MPU'ya uzaklığına göre yakından uzağa doğru 100 – 107 arası adreslenir.
Çalışma/Saklama Sıcaklığı	Çalışma: 0 to 55°C (sıcaklık), 50 to 95% (rutubet), kirlenme derece 2 Saklama: -25 to ~70°C (sıcaklık), 5 to 95% (rutubet)
Titreşim / Şok Bağışıklığı	Uluslararası standartlar: IEC61131-2, IEC 68-2-6 (TEST Fc)/ IEC61131-2 & IEC 68-2-27 (TEST Ea)

- ❖ DIN1319-1 ile uyumlu, ölçüm değeri toleransı 20°C + 10K sıcaklık aralığında ≤ 0.05 % olmalıdır.
- ❖ Düzeltilmiş sıcaklık ortamı ve gerçek sıcaklık arasında 10°C'den fazla fark varsa, tekrar düzeltilmesi önerilir.

■ Kontrol Register

CR#	Adres	Özellik	Register adı	Açıklama
#0	H1000	O R	Model adı	Sistem tarafından ayarlanır: DVP01LC-SL model kodu = H'4106
#1	H1001	O R	Yazılım versiyonu	Mevcut yazılım versiyonunu Hex. Olarak gösterir.
#2	H1002	O RW	Karakteristik Değer	Mod 0 (H'0000): 1 mV/V Mod 1 (H'0001): 2 mV/V, varsayılan Mod 2 (H'0002): 4 mV/V Mod 3 (H'0003): 6 mV/V
#3	H1003	O RW	Ölçüm için tepki zamanı	Mod 0 (H'0000): 2 ms Mod 1 (H'0001): 10 ms Mod 2 (H'0002): 20 ms Mod 3 (H'0003): 40 ms Mod 4 (H'0004): 80 ms, varsayılan
#6	H1006	X RW	CH1 dara okuma komutu	Mevcut okunan ağırlık değerini dara ağırlığı olarak okumak içindir. bit0: CH1
#7	H1007	O RW	Bürüt/Net ağırlık seçimi	Mevcut ağırlığı Bürüt ağırlık (K0) veya Net (K1) ağırlık olarak gösterir.

CR#	Adres	Özellik		Register adı	Açıklama
#10	H100A	O	RW	CH1 ortalama adeti	Varsayılan: K10; Aralık: K1 ~ K100. Set değeri aralığı aştığı zaman, otomatik olarak K1 ve K100 olarak değişir.
#12	H100C	X	R	CH1 okunan ağırlık değeri (Düşük word)	Ağırlığı gösterir. Varsayılan: K0
#13	H100D	X	R	CH1 okunan ağırlık değeri (Yüksek word)	Ağırlığı gösterir. Varsayılan: K0
#16	H1010	O	RW	CH1 durgunluk adeti	Varsayılan: K5; Aralık: K1~K500
#18	H1012	O	RW	CH1 durgunluk aralığı	Varsayılan: K10; Aralık: K1~K10,000
#20	H1014	O	RW	CH1 ondalık yeri	Varsayılan: K2; Aralık: K1~K4
#22	H1016	O	RW	CH1 ölçüm birimi	Maksimum 4 ASCII word girilir.
#23	H1017	O	RW	CH1 ölçüm birimi	CR#22, CR#24: Yüksek word CR#23, CR#25: Düşük word
#26	H101A	X	RW	Ağırlık düzeltme komutu	Kullanıcıların ağırlığı düzeltmesi için. Varsayılan: H'0000 H'0001: CH1 okunan ağırlığı sıfıra resetle H'0002: CH1 ağırlık düzeltme komutu
#33	H1021	O	RW	CH1 ağırlık düzeltme değeri	CR#33~CR#34 için Varsayılan = K1,000; Aralık: K-32,768 ~ K32,767 Düzeltilme adımları: CH1 örneği 1: Load cell üzerine hiçbir ağırlık koymayınız. 2: CR#26 komutunu "H'0001" ayarlayınız. 3: Load cell üzerine standart ağırlığı yerleştiriniz 4: Tabaka üzerindeki ağırlığı ikinci ağırlık değeri olarak CR#33 içine yazınız. 5: CR#26 komutunu "H'0002" ayarlayınız
#35	H1023	O	R	CH1 max. ağırlık (Düşük word)	Maksimum ağırlık ayarı. Ölçüm değeri kullanıcı tarafından set edilen değeri aştığı zaman, hata kodları içerisine kaydedilecek.
#36	H1024	O	R	CH1 max. ağırlık (Yüksek word)	
#37	H1025	O	RW	CH1 sıfır noktası kontrol üst limiti	Sıfır durumuna karar vermek için referans. Ağırlık bu aralığın içinde olduğu zaman, durum kodu mevcut ağırlık durumunu "ağırlık sıfır (boş)" olarak gösterir. Varsayılan: K10 Aralık: K-32,768 ~ K32,767
#39	H1027	O	RW	CH1 sıfır noktası kontrol alt limiti	Sıfır durumuna karar vermek için referans. Ağırlık bu aralığın içinde olduğu zaman, durum kodu mevcut ağırlık durumunu "ağırlık sıfır (boş)" olarak gösterir. Varsayılan: K-10 Aralık: K-32,768 ~ K32,767

CR#	Adres	Özellik	Register adı	Açıklama
#41	H1029	X R/W	Ayarlanan değerleri kaydetme (H'5678)	Mevcut set değerlerini kalıcı olarak kaydeder ve DVP01LC-SL daha sonra enerjilendiğinde kullanabilmesi için tüm set değerlerini dahili flash memory içine yazar. H0: Çalışma yok (Varsayılan) H'FFFF: Kayıt başarılı H'5678: Dahili Flash memory içerisine yazar. H'5678 ile yazıldığı zaman, tüm set değerleri Flash memory içine kaydedilecek. Kayıt tamamlandığı zaman, CR#41 H'FFFF olacak. Eğer yazılan değer H'5678 değilse, otomatik olarak H0'a dönecek. Örneğin CR# içine K1 yazılırsa K0'a dönecek.
#43	H102B	X R/W	CH1 filtre yüzdesi	Varsayılan: K2; Aralık: K1 ~ K9 (Birim: 10%)
#50	H1032	X R	Durum kodu	b0 (H'0001): CH1 ağırlık sıfır (boş) b2 (H'0004): CH1 ağırlığı maksimum değer aşması (aşırı yük) b4 (H'0010): CH1 ölçüm değeri stabil b6 ~ b15: Rezerve
#51	H1033	X R	Hata kodu	Tüm hata durumlarını kaydeder. Lütfen aşağıdaki "Hata kodu tablosu" na bakınız. Varsayılan: H'0000
#52	H1034	O R/W	RS-232 istasyon adresi	CR#52, CR#54 için Varsayılan = 1; Aralık: K1~ K255 CR#53, CR#55 için Varsayılan = H'0000; Aralık: ASCII, 9600, 7, E, 1. "Haberleşme Formatı Tablosu" na bakınız.
#53	H1035	O R/W	RS-232 haberleşme formatı	
#54	H1036	O R/W	RS-485 istasyon adresi	
#55	H1037	O R/W	RS-485 haberleşme formatı	
Semboller: O: Kalıcı; X: Kalıcı-değil; R: Okunabilir data; W: Yazılabilir data.				

▲ CR#51 için Hata Kodu Tablosu:

bit	Değer	Hata	bit	Değer	Hata
b0	K1 (H'0001)	Power supply anormal.	b1	K2 (H'0002)	Donanım hatası.
b2	K4 (H'0004)	CH1 dönüşüm hatası	b3	K8 (H'0008)	CH1 SEN voltaj hatası.
b6 ~ b15	K64 (H'0040)	Rezerve			
✍Not: Her hata durumu ona karşılık gelen bir bit ile tanımlanır. Aynı anda 2 veya daha fazla hata meydana gelebilir. 0 hata olmadığını; 1 hata olduğunu gösterir.					

▲ CR#53, CR#55 için Haberleşme Formatı Tablosu:

bit15	bit14 ~ bit8	bit7	bit6	bit5	bit4	bit3	bit2	bit1	bit0
ASCII/RTU	Rezerve	Baudrate			Data Uzunluğu		Stop bit	Parity	
Açıklama									
bit15	ASCII / RTU			0	ASCII	1	RTU		
bit7 ~ bit4	Baudrate	0	9,600 bps		1	19,200 bps			
		2	38,400 bps		3	57,600 bps			
		4	115,200 bps		5	Else none			
bit3	Data uzunluğu (RTU = 8 bits)			0	7	1	8		
bit2	Stop bit			0	1 bit	1	2 bits		
bit1 ~ bit0	Parity	0	Even		1	Odd			
		2	None		3	None			